

Wide Flange Shape

Product Specifications

Hot Rolled

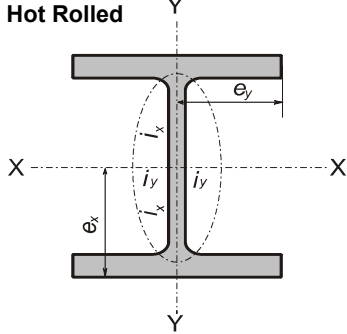

Geometrical moment of inertia $I = Ai^2$
Radius of gyration of area $I = \sqrt{I/A}$
Modulus of section $z = I/e$
(A = sectional area)

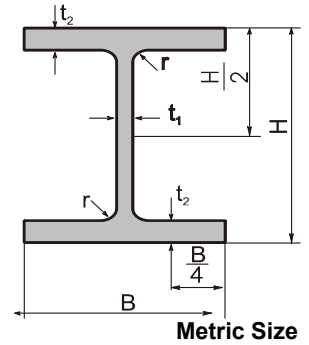

According JIS G 3192

Metric Size

Standard Sectional Dimension					Section Area A cm ²	Unit Weight kg/m	Informative Reference					
Nominal Dimensional mm	H x B mm	t ₁ mm	t ₂ mm	r mm			Geometrical Moment Of Inertia		Radius Of Gyration Of Area		Modulus Of Section	
							I _x cm ⁴	I _y cm ⁴	i _x cm	i _y cm	Z _x cm ³	Z _y cm ³
100 x 100	100 x100	6	8	10	21.90	17.20	383	134	4.18	2.47	76.50	26.7
125 x125	125 x125	6.5	9	10	30.31	23.80	847	293	5.29	3.11	136.00	47.00
150 x 75	150 x75	5	7	8	17.85	14.00	666	50	6.11	1.66	8.88	13.20
150 x 100	150 x100	6	9	11	26.84	21.10	1,020	151	6.17	2.37	138.00	30.10
150 x 150	150 x150	7	10	11	40.14	31.50	1,640	563	6.39	3.75	219.00	75.10
175 x 175	175 x175	7.5	11	12	51.21	40.20	2,880	984	7.50	4.38	330.00	112.00
200 x 100	198 x 99	4.5	7	11	23.18	18.20	1,580	114	8.26	2.21	160.00	23.00
	200 x 100	5.5	8	11	27.16	21.30	1,840	134	8.24	2.22	184.00	26.80
200 x 150	194 x 150	6	9	12	38.80	30.60	2,675	507	8.30	3.60	275.80	67.60
200 x 200	200 x 200	8	12	13	63.53	49.90	4,720	1,600	8.62	5.02	472.00	160.00
250 x 125	248 x 124	5	8	12	32.68	25.70	3,540	255	10.40	2.79	285.00	41.10
	250 x 125	6	9	12	37.66	29.60	4,050	294	10.40	2.79	324.00	47.00
250 x 250	250 x 250	9	14	16	92.18	72.40	10,800	3,650	10.80	6.29	867.00	292.00
300 x 150	298 x 149	5.5	8	13	40.80	32.00	6,320	442	12.40	3.29	424.00	59.30
	300 x 150	6.5	9	13	46.78	36.70	7,210	508	12.40	3.29	481.00	67.70
300 x 300	300 x 300	10	15	18	119.80	94.00	20,400	6,750	13.10	7.51	1,360.00	450.00
350 x 175	346 x 174	6	9	14	52.68	41.40	11,100	792	14.50	3.88	641.00	91.00
	350 x 175	7	11	14	63.14	49.60	13,600	984	14.70	3.95	775.00	112.00
350 x 350	350 x 350	12	19	20	173.9	137.00	40,300	13,600	15.20	8.84	2,300.00	776.00
400 x 200	396 x 199	7	11	16	72.16	56.60	20,000	1,450	16.70	4.48	1,010.00	145.00
	400 x 200	8	13	16	84.1	66.00	23,700	1,740	16.80	4.54	1,190.00	174.00
400 x 400	400 x 400	13	21	22	218.7	172.00	66,600	22,400	17.50	10.10	3,330.00	1120.00
450 x 200	450 x 200	9	14	18	96.8	76.00	33,500	1,870	18.60	4.40	1,490.00	187.00
500 x 200	500 x 200	10	16	20	114.2	89.60	47,800	2,140	20.50	4.33	1,910.00	214.00
600 x 200	600 x 200	11	17	22	134.4	106.00	77,600	2,280	24.00	4.12	2,590.00	228.00
600 x 200	588 x 300	12	20	28	192.5	151.00	118,000	9,020	24.80	6.85	4,020.00	601.00
700 x 300	700 x 300	13	24	28	235.5	185.00	201,000	10,800	29.30	6.78	5,760.00	722.00
800 x 300	800 x 300	14	26	28	267.4	210.00	292,000	11,700	33.00	6.62	7,290.00	782.00
900 x 300	900 x 300	16	28	28	309.8	243.00	411,000	12,600	36.40	6.39	9,140.00	843.00

Wide Flange Shape

Dimensional Tolerances

According JIS G 3192

Item, mm (in.)		Tolerance	Remarks	
Width (B)		± 3.0 (0.118)		
Depth (H)		Nominal depth of under 400 (15.748)		± 3.0 (0.118)
		400 to 600 (23.622), excl.		± 4.0 (0.157)
		600 and over		± 5.0 (0.197)
Thickness	Flange t^2	Under 16		± 1.5 (0.059)
		16 or over to and excl. 25		± 2.0 (0.079)
		25 or over to and excl. 40		± 2.5 (0.098)
		40 or over		± 3.0 (0.118)
	Web t^1	Under 16		± 1.0 (0.039)
		16 or over to and excl. 25		± 1.5 (0.024)
Length		7 m or under	+ 40 (1.575) - 0	
		Over 7 m	40 (1.575) plus 5 (0.197) for each additional meter or fraction thereof	
Out-of-Square (T)		Nominal depths 300 (11.811) or under in nominal depth	Not more than 1.2 percent of flange width B or 2.0 (0.079) at minimum.	
		Nominal depths Over 300 (11.811) in nominal depth	Not more than 1.5 percent of flange width B or 2.0 (0.079) at minimum.	
Chamber of Sweep		Nominal depths 300 (11.811) and under	Not more than 0.20 percent of Length.	
		Nominal depths Over 300 (11.811)	Not more than 0.10 percent of Length.	
Web Off Centre (S)		Nominal depths 300 (11.811) and under	± 3.0 (0.118)	
		Nominal depths Over 300 (11.811)	± 4.5 (0.117)	
Ends Out of Square (e)		1.6% or under of width B or of depth H, provided that 3.0mm is the minimum		

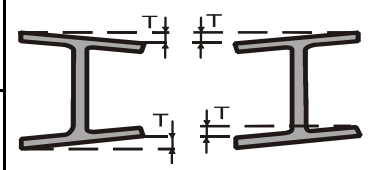
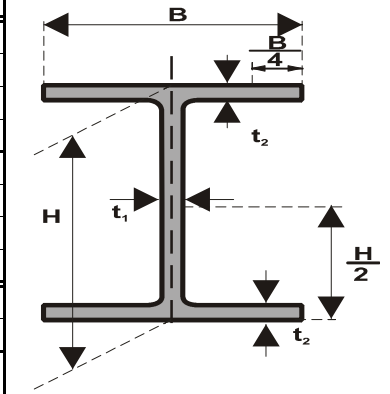

Horizontal or Vertical Curvature in the direction of length

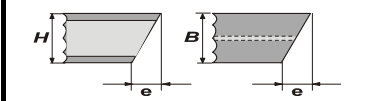
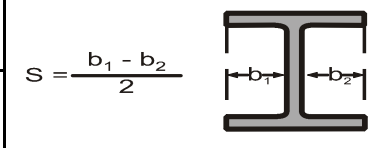

Wide Flange Shape

Chemical Composition

Symbol Of Grade	Chemical Composition				
	C	Si	Mn	P	S
SS 400	-	-	-	0.050 max	0.050 max
SM 490 YA	0.20 Max	0.55 Max	1.60 Max	0.035 Max	0.035 Max
SM 490 YB					

Wide Flange Shape

Chemical Composition

Type Of Material	Classified by Tensile Strength		Specifications			
	Tensile Strength Class (N/mm)	Special Specification	JIS	ASTM	BS 4360	DIN
Steel Structure	400	-	G 3101 SS400	A 36	Gr. 43A	St 33

Wide Flange Shape

Mechanical Properties

Classification	Yield Point/mm ²		Tensile Strength	Elongation (%)		
	Thickness			Thickness of Steel Products (mm)		
	16 or under	>16 up to 40	N/mm ²	5 or under	5 to 6	>6 up to 50
JIS G3101 SS 400	245 min	235 min	400 - 510	21 min	17 min	21 min
JIS G3106 SM 490 YA SM 490 YB	365 min	355 min	490 - 610	19 min	15 min	19 min

Wide Flange Shape

Table Weight

Specification : JIS G3101 SS400.

Size	Kg/M	Kg/12M
------	------	--------

Hot Rolled Beam / WF

IWF	150	x	75	x	5	x	7	14	168
IWF	198	x	99	x	4.5	x	7	18.2	218
WF	148	x	100	x	6	x	9	21.1	253
IWF	200	x	100	x	5.5	x	8	21.3	256
IWF	248	x	124	x	5	x	8	25.7	308
IWF	250	x	125	x	6	x	9	29.6	355
WF	194	x	150	x	6	x	9	30.6	367
IWF	298	x	149	x	5.5	x	8	32	384
IWF	300	x	150	x	6.5	x	9	36.7	440
IWF	346	x	174	x	6	x	9	41.4	497
IWF	350	x	175	x	7	x	11	49.6	595
IWF	396	x	199	x	7	x	11	56.6	679
IWF	400	x	200	x	8	x	13	66	792
IWF	450	x	200	x	9	x	14	76	912
IWF	500	x	200	x	10	x	16	89.6	1,075
IWF	600	x	200	x	11	x	17	106	1,272
IWF	588	x	300	x	12	x	20	151	1,812

Hot Rolled Beam / H-Beam

HB	100	x	100	x	6	x	8	17.2	206
HB	125	x	125	x	6.5	x	9	23.8	286
HB	150	x	150	x	7	x	10	31.5	378
HB	175	x	175	x	7.5	x	11	40.2	482
HB	200	x	200	x	8	x	12	49.9	599
HB	250	x	250	x	9	x	14	72.4	869
HB	300	x	300	x	10	x	15	94	1128
HB	350	x	350	x	12	x	19	137	1644

Hot Rolled Beam / WF In Inch

UB	467	x	192.8	x	11.4	x	19.6	98.3	1,179.60
UB	463	x	191.9	x	10.5	x	17.7	89.3	1,071.60
UB	460	x	191.3	x	9.9	x	16	82	984.00
UB	457	x	190.4	x	9	x	14.5	74.3	891.60
UB	453	x	189.9	x	8.5	x	12.7	67.1	805.20
UB	466	x	155.3	x	10.5	x	18.9	82.1	985.20
UB	462	x	154.4	x	9.6	x	17	74.2	890.40
UB	458	x	153.8	x	9	x	15	67.2	806.40
UB	455	x	152.9	x	8.1	x	13.3	59.8	717.60
UB	450	x	152.4	x	7.6	x	10.9	52.3	627.60
UB	413	x	179.5	x	9.5	x	16	74.2	890.40
UB	409	x	178.8	x	8.8	x	14.3	67.1	805.20
UB	406	x	177.9	x	7.9	x	12.8	60.1	721.20
UB	403	x	177.7	x	7.7	x	10.9	54.1	649.20
UB	363	x	173.2	x	9.1	x	15.7	67.1	805.20
UB	358	x	172.2	x	8.1	x	13	57	684.00
UB	355	x	171.5	x	7.4	x	11.5	51	612.00
UB	351	x	171.1	x	7	x	9.7	45	540.00
UB	310	x	166.9	x	7.9	x	13.7	54	648.00
UB	307	x	165.7	x	6.7	x	11.8	46.1	553.20
UB	303	x	165	x	6	x	10.2	40.3	483.60
UB	260	x	147.3	x	7.2	x	12.7	43	516.00
UB	256	x	146.4	x	6.3	x	10.9	37	444.00

Wide Flange Shape

Table Weight

Specification : JIS G3101 SS400.

Size					Kg/M	Kg/12M			
UB	251	x	146.1	x	6	x	8.6	31.1	373.20
UB	207	x	133.9	x	6.4	x	9.6	30	360.00
UB	203	x	133.2	x	5.7	x	7.8	25.1	301.20
UB	127	x	76	x	4	x	7.6	13	156.00
UC	222	x	209.1	x	12.7		20.5	86.1	1,033.20
UC	216	x	206.4	x	10		17.3	71	852.00
UC	210	x	205.8	x	9.4		14.2	60	720.00
UC	206	x	204.3	x	7.9		12.5	52	624.00
UC	203	x	203.6	x	7.2		11	46.1	553.20
UC	162	x	154.4	x	8		11.5	37	444.00
UC	158	x	152.9	x	6.5		9.4	30	360.00
UC	152	x	152.2	x	5.8		6.8	23	276.00